

0.1



DPG7340*

a

0.1.1

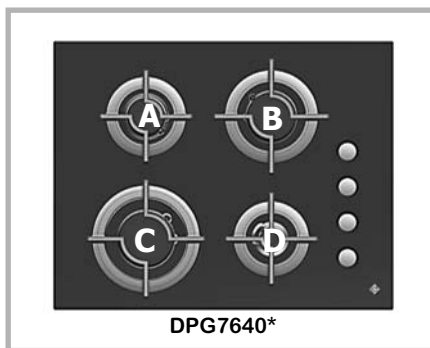

DPG7640*

b

0.1.2

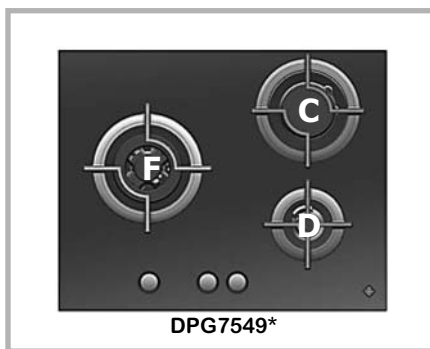

DPG7549*

c

0.1.3

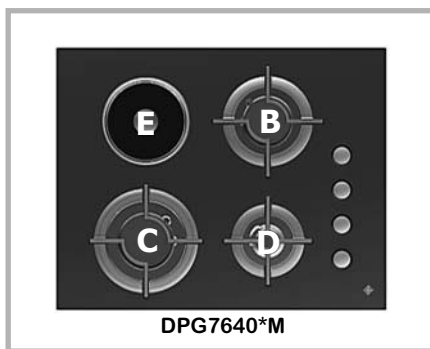

DPG7640*M

d

0.1.4

A 1,50 kW / G20

B 2,25 kW / G20

C 3,10 kW / G20

D 0,85 kW / G20

E 1,50 kW / Ø145

F 3,8 kW / G20

1

1.1

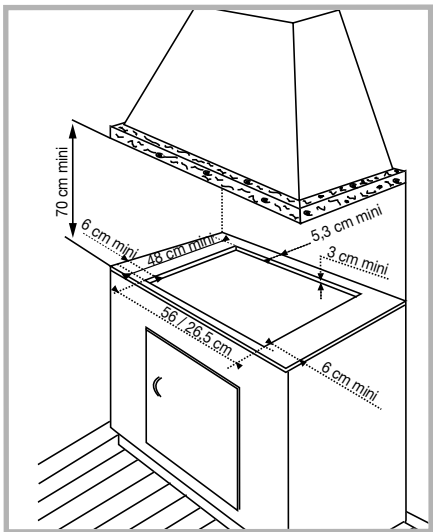

1.1.1

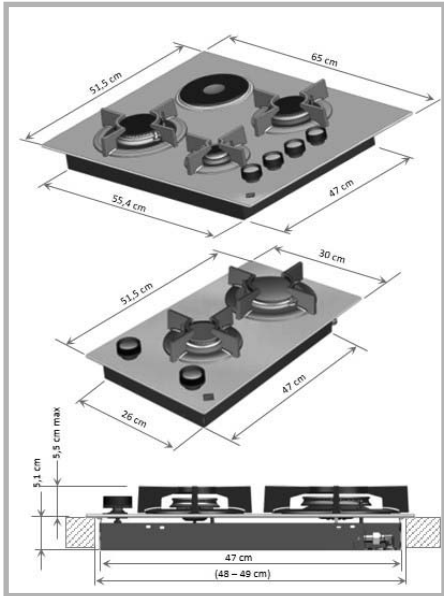

1.1.2

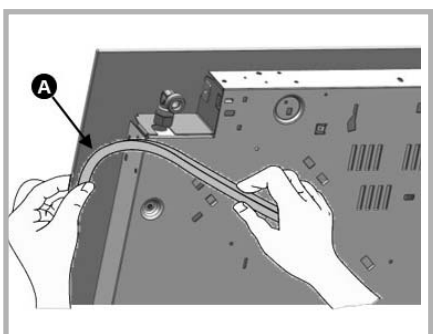

1.1.3

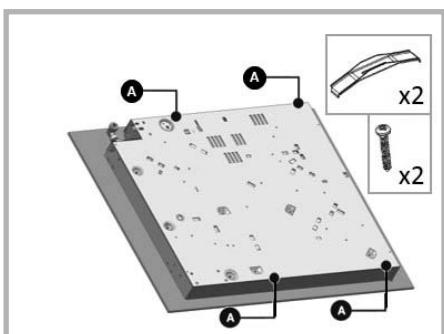

1.1.4

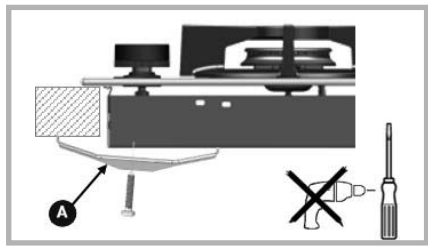

1.1.5

1

1.2

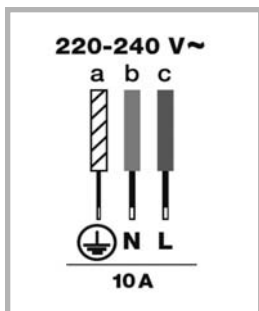

1.2.1

1.3

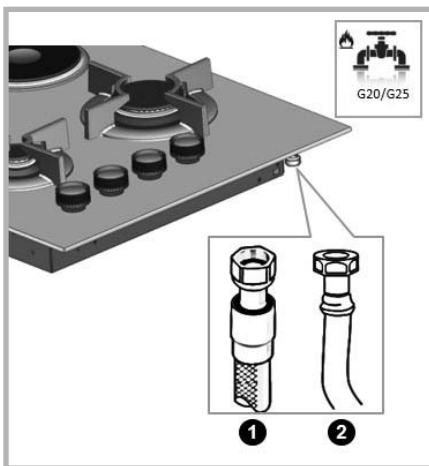

1.3.1

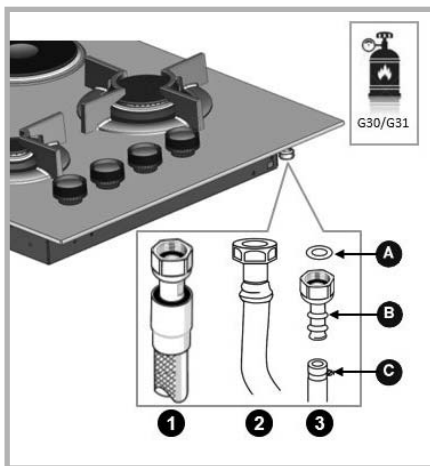

1.3.2

1.4

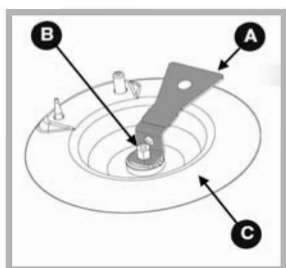

1.4.1

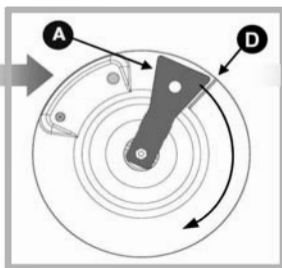

1.4.2

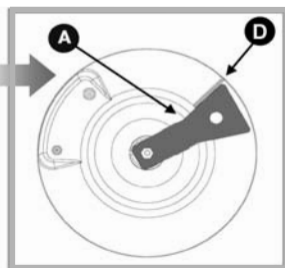

1.4.3

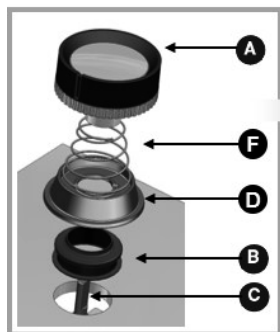

1.4.4

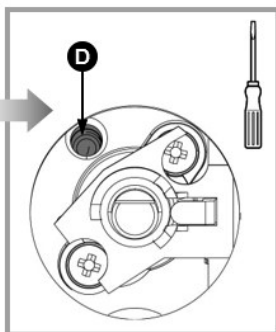

1.4.5

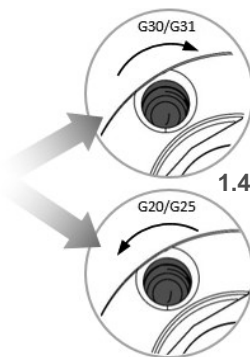







1.4.5.1

1.4.5.2

1.5

	FR / EN / ES / PT / DE / DA / EL / IT / SV / CS / NL / PL / SK
G20 / G25	Gaz naturel / Natural gas / Gas natural / gás natural / Erdgas / Naturgas / Φυσικό αέριο / Gas naturale / Naturgas / Zemní plyn / Aardgas / Gaz ziemny / zemný plyn
G30	Butane / Butane / Butano / Butano / Butan / Butangas / Βουτανίου / Butano / Butan / Butan / Butaan / Butan / Bután
G31	Propane / Propane / Propano / Propano / Propangas / Propangas / Προπανίου / Propano / Propan / Propan / Propan / Propan / Propán

	FRCat II2E+3+	GAS	mbar	Σ Qn (kw)	Σ l/h	Σ g/h
a		G30	28-30	4,65		338
		G31	37	4,65		332
		G20	20	4,60	438	
		G25	25	4,60	509	
b		G30	28-30	7,50		545
		G31	37	7,50		536
		G20	20	7,70	733	
		G25	25	7,70	852	
c		G30	28-30	7,10		516
		G31	37	7,10		507
		G20	20	7,75	738	
		G25	25	7,75	858	
d		G30	28-30	6,00		436
		G31	37	6,00		429
		G20	20	6,20	590	
		G25	25	6,20	686	

	Gas	mbar		Qn (kW)	l/h	g/h	Qr (kW)
D 	G30	28-30	45	0,70		51	0,30
	G31	37	45	0,70		50	
	G20	20	63	0,85	81		0,35
	G25	25	63	0,85	94		0,35
A 	G30	28-30	62	1,50		109	0,62
	G31	37	62	1,50		107	
	G20	20	94	1,50	143		0,615
	G25	25	94	1,50	166		0,615
B 	G30	28-30	7R	2,15		156	0,83
	G31	37	7R	2,15		154	
	G20	20	1R	2,25	214		0,87
	G25	25	1R	2,25	249		0,87
C 	G30	28-30	88A	3,15		229	0,83
	G31	37	88A	3,15		225	
	G20	20	137	3,10	295		0,87
	G25	25	137	3,10	343		0,87
F 	G30	28-30	60/37/60	3,25		236	1,65
	G31	37	60/37/60	3,25		232	
	G20	20	092/055B/092	3,80	362		1,65
	G25	25	092/055B/092	3,80	421		1,65

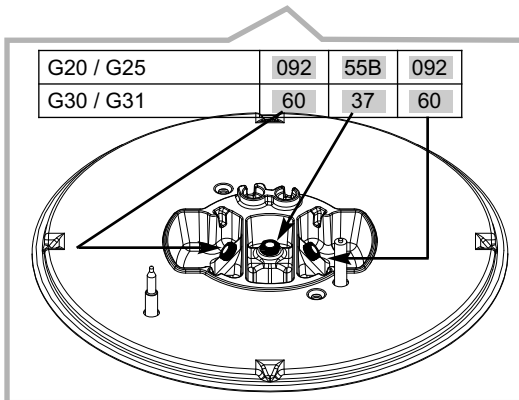

• 1

1.6

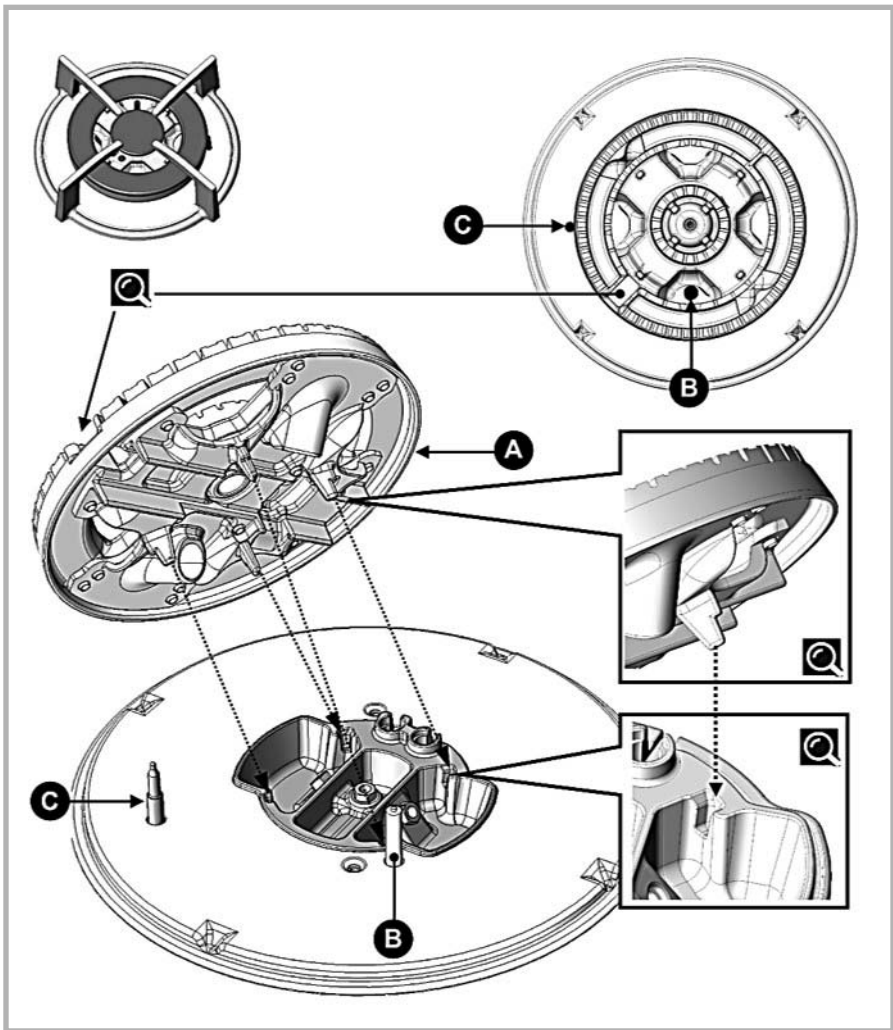

• 2

2.1



2.1.1



2.1.2

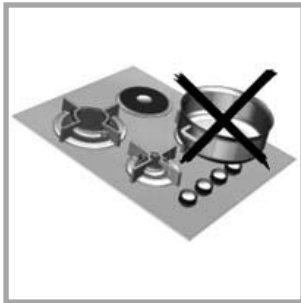

2.1.3

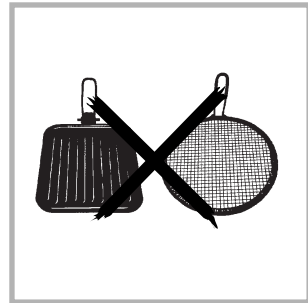

2.1.4

2.3

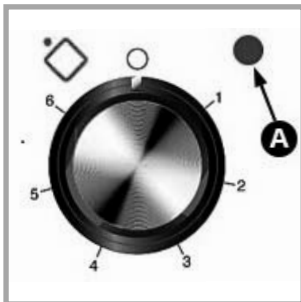

2.3.1

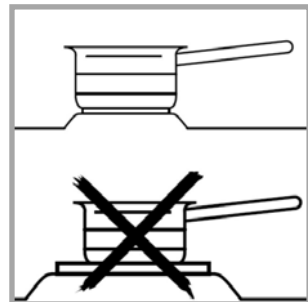

2.3.2

• 3

3.1

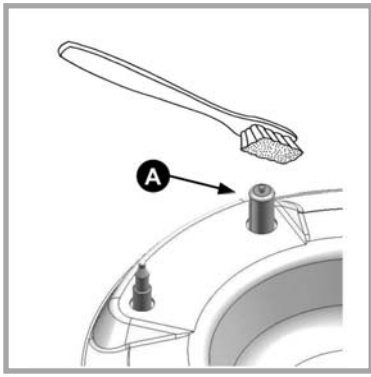

3.1.1

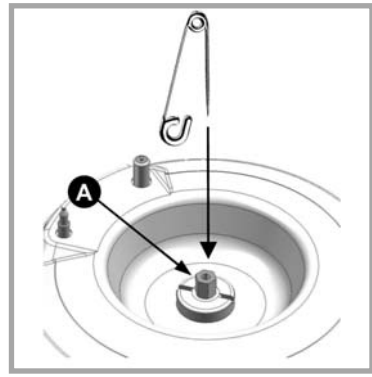

3.1.2

• 6

6.1

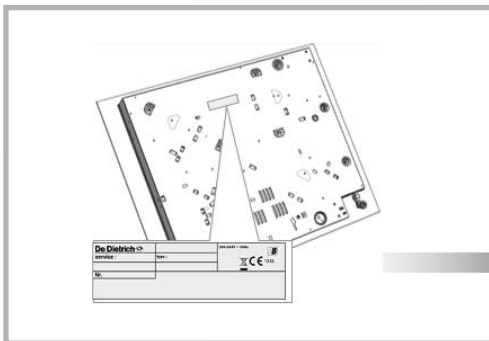

6.1.1

Service:

Type: